

Production Worksheet

Wilcom EmbroideryStudio - Designing



Design: **Design1**

Title:

Stitches: 4,231
 Height: 2.02 in
 Width: 2.06 in
 Colors: 2
 Colorway: Colorway 1
 Zoom: 1:1

Machine format: Janome
 Color changes: 1
 Stops: 2
 Trims: 2
 Appliqués: 0
 Left: 26.2 mm
 Right: 26.2 mm
 Up: 25.6 mm
 Down: 25.6 mm
 EndX: 0.18 in
 EndY: 0.14 in
 Area 4.16 in²
 Max stitch: 9.0 mm
 Min stitch: 0.3 mm
 Max jump: 0.0 mm
 Total thread: 87.15ft
 Total bobbin: 34.80ft

Stop Sequence:

#	N#	Color	St.	Code	Name	Chart
1.	16		3,994	0	R254 G254 B254	User-defined
2.	17		236	0	R250 G200 B10	User-defined

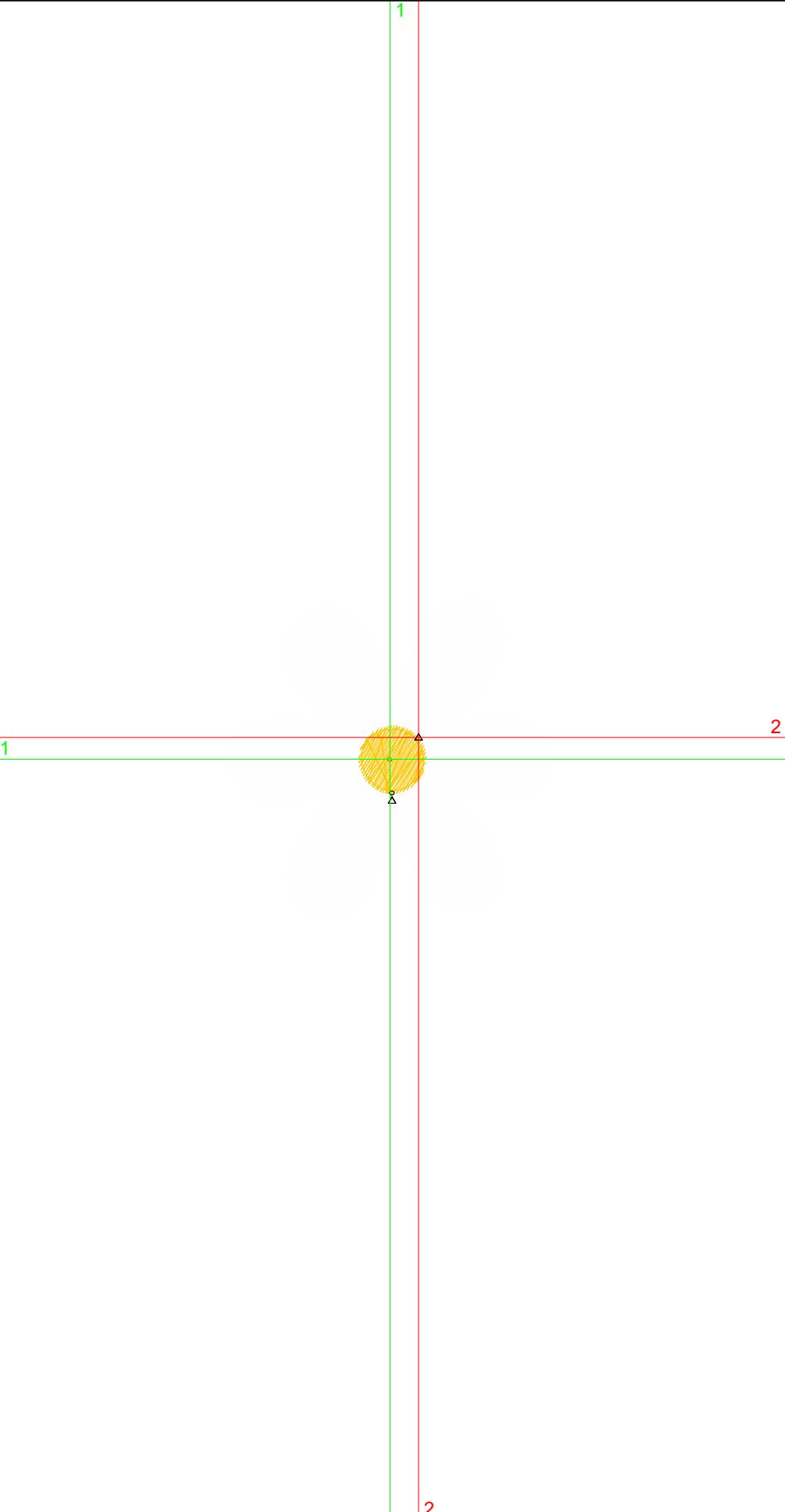

Production Worksheet

Wilcom EmbroideryStudio - Designing



Design: **Design2**

Title:

Stitches: 3,131
 Height: 1.62 in
 Width: 1.60 in
 Colors: 2
 Colorway: Colorway 1
 Zoom: 1:1

Machine format: Janome
 Color changes: 1
 Stops: 2
 Trims: 2
 Appliqués: 0
 Left: 20.3 mm
 Right: 20.3 mm
 Up: 20.5 mm
 Down: 20.6 mm
 EndX: 0.17 in
 EndY: 0.17 in
 Area: 2.59 in²
 Max stitch: 10.0 mm
 Min stitch: 0.3 mm
 Max jump: 10.0 mm
 Total thread: 62.02ft
 Total bobbin: 24.18ft

Stop Sequence:

#	N#	Color	St.	Code	Name	Chart
1.	16		2,873	0	R254 G254 B254	User-defined
2.	17		257	0	R250 G200 B10	User-defined

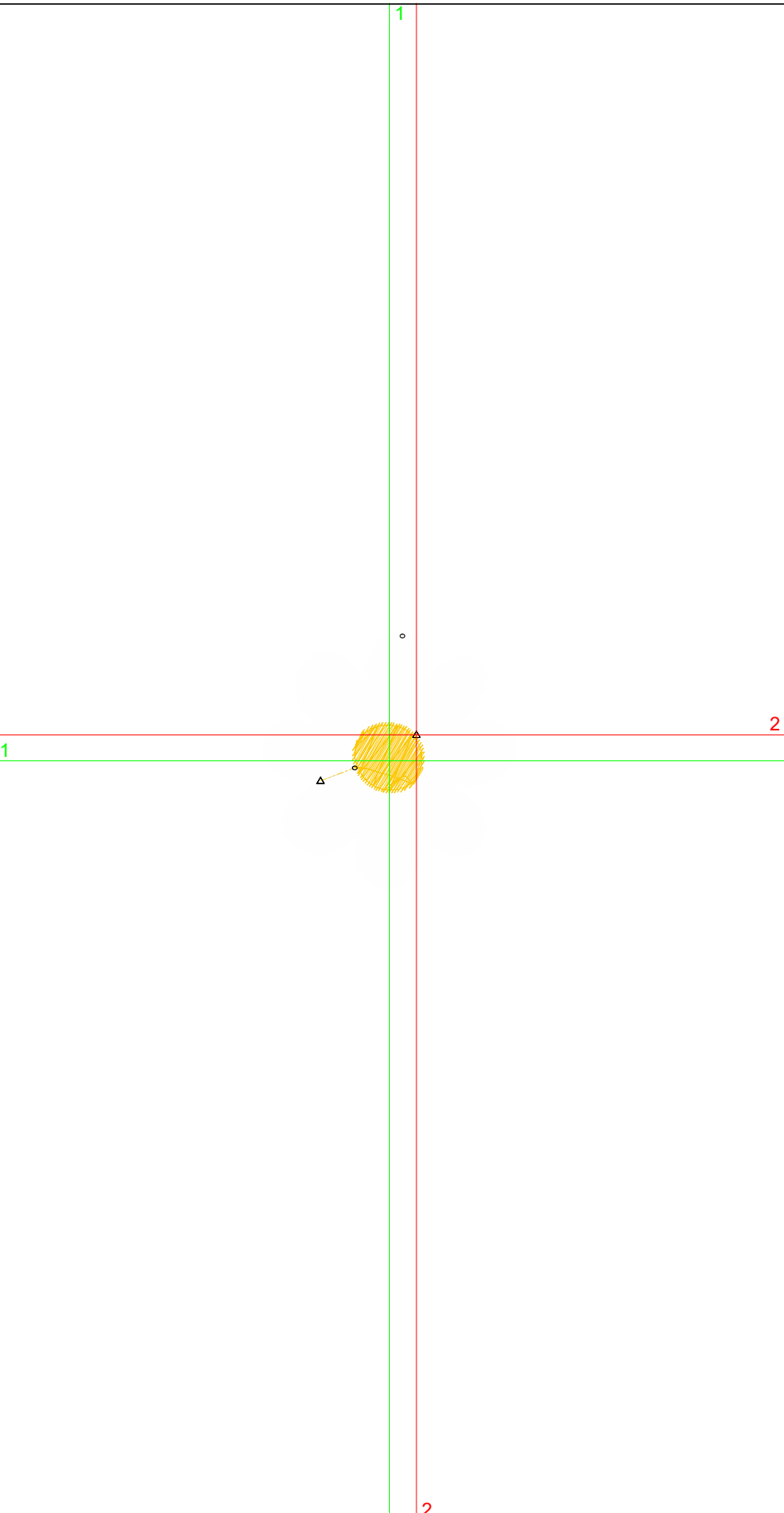

Production Worksheet

Wilcom EmbroideryStudio - Designing



Design: **Design3**

Title:

Stitches: 1,445
 Height: 1.06 in
 Width: 1.05 in
 Colors: 2
 Colorway: Colorway 1
 Zoom: 1:1

Machine format: Janome
 Color changes: 1
 Stops: 2
 Trims: 2
 Appliqués: 0
 Left: 13.3 mm
 Right: 13.3 mm
 Up: 13.4 mm
 Down: 13.4 mm
 EndX: -0.25 in
 EndY: -0.05 in
 Area: 1.10 in²
 Max stitch: 6.7 mm
 Min stitch: 0.3 mm
 Max jump: 6.7 mm
 Total thread: 24.46ft
 Total bobbin: 8.48ft

Stop Sequence:

#	N#	Color	St.	Code	Name	Chart
1.	16		1,145	9	White	User-defined
2.	17		299	0	R250 G200 B10	User-defined

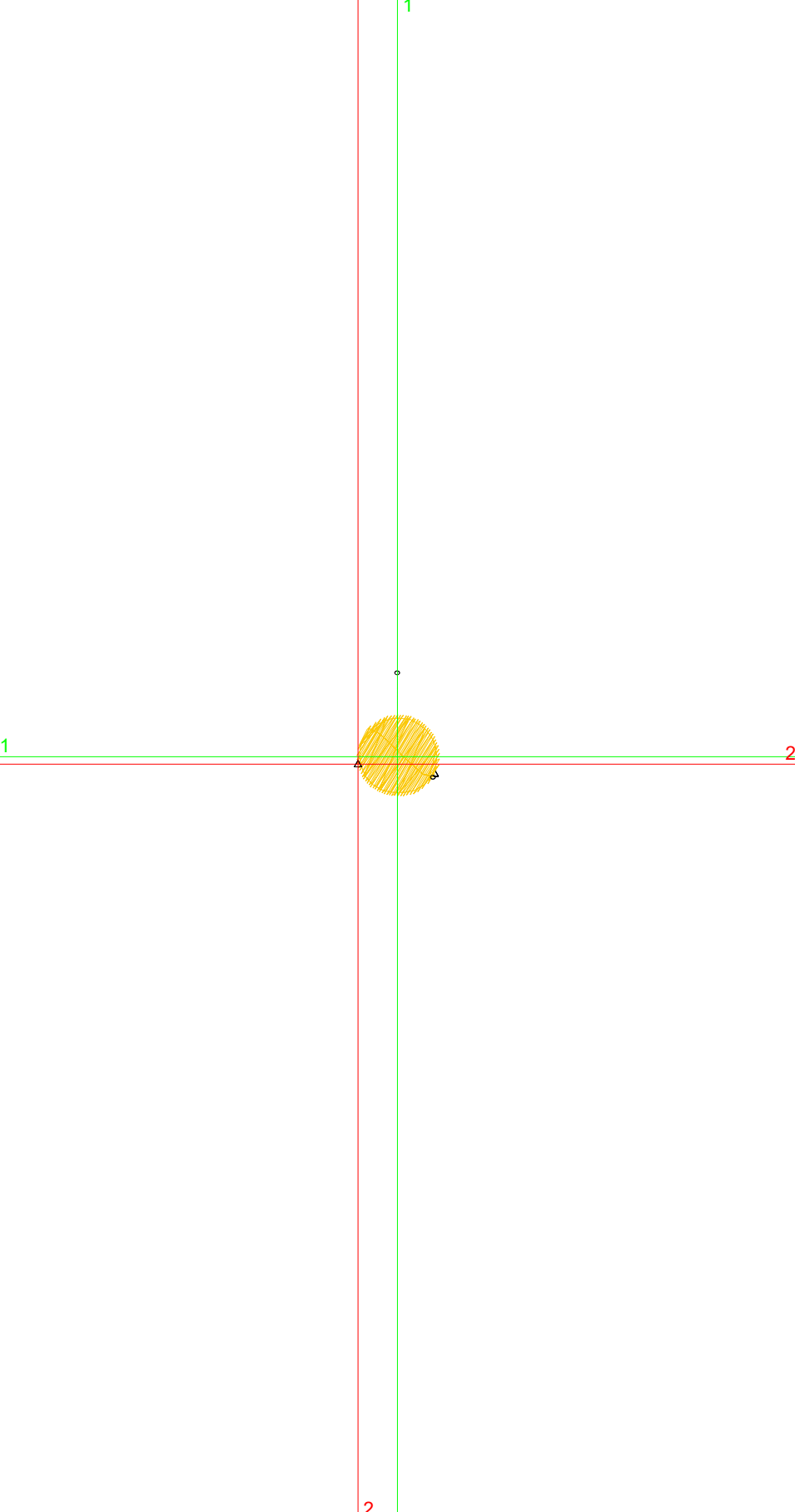

Production Worksheet

Wilcom EmbroideryStudio - Designing



Design: **Design4**

Title:

Stitches: 1,269
 Height: 0.90 in
 Width: 0.93 in
 Colors: 2
 Colorway: Colorway 1
 Zoom: 1:1

Machine format: Janome
 Color changes: 1
 Stops: 2
 Trims: 4
 Appliqués: 0
 Left: 11.8 mm
 Right: 11.8 mm
 Up: 11.4 mm
 Down: 11.4 mm
 EndX: -0.26 in
 EndY: -0.07 in
 Area 0.83 in²
 Max stitch: 6.7 mm
 Min stitch: 0.3 mm
 Max jump: 1.9 mm
 Total thread: 20.93ft
 Total bobbin: 7.08ft

Stop Sequence:

#	N#	Color	St.	Code	Name	Chart
1.	16		323	0	R249 G200 B10	User-defined
2.	17		945	0	R254 G254 B254	User-defined

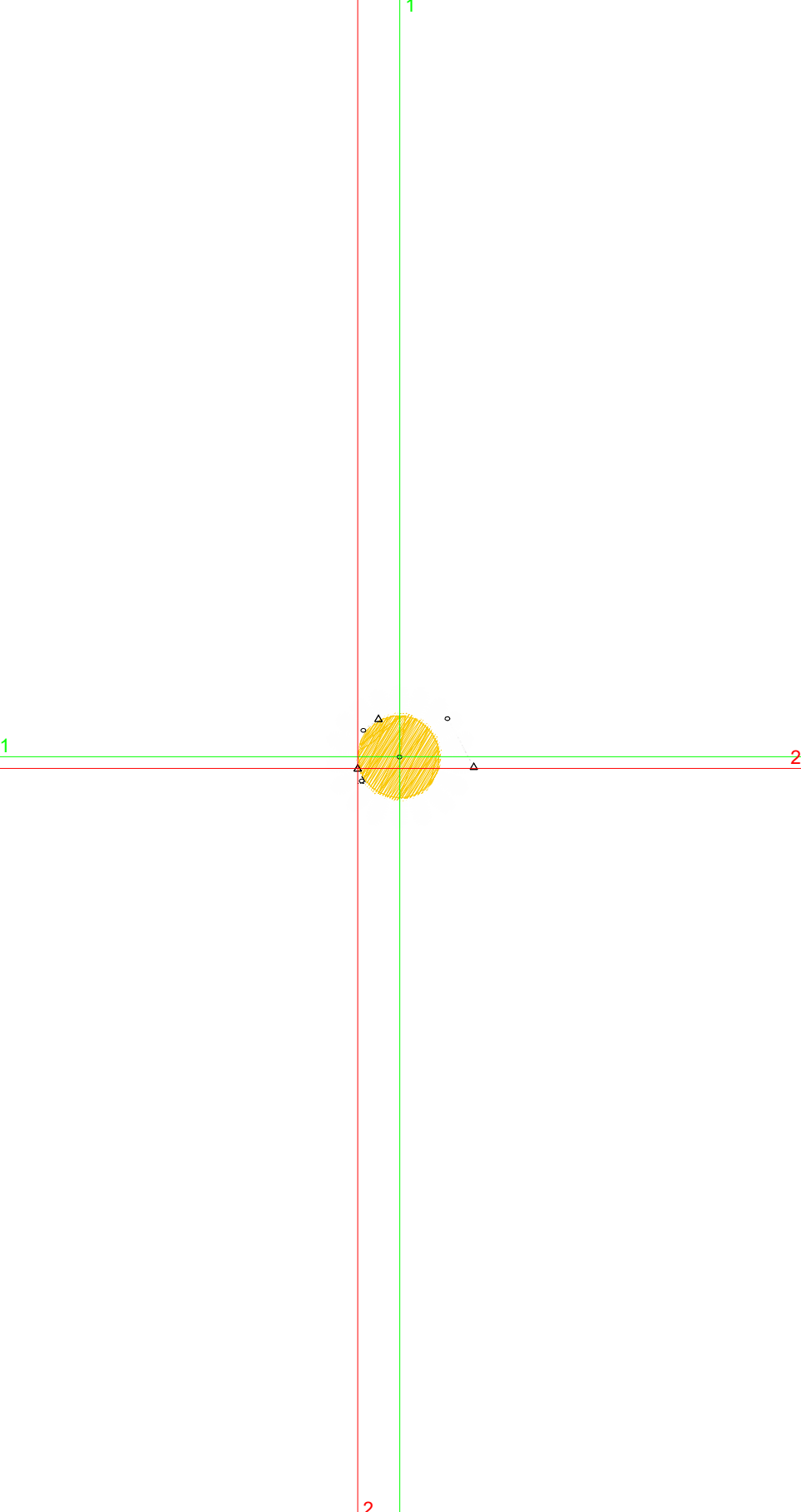

Production Worksheet

Wilcom EmbroideryStudio - Designing



Design: **Design5**

Title:

Stitches: 705
 Height: 0.73 in
 Width: 0.71 in
 Colors: 2
 Colorway: Colorway 1
 Zoom: 1:1

Machine format: Janome
 Color changes: 1
 Stops: 2
 Trims: 2
 Appliqués: 0
 Left: 9.1 mm
 Right: 9.0 mm
 Up: 9.3 mm
 Down: 9.3 mm
 EndX: -0.01 in
 EndY: -0.11 in
 Area 0.52 in²
 Max stitch: 5.2 mm
 Min stitch: 0.4 mm
 Max jump: 0.0 mm
 Total thread: 12.63ft
 Total bobbin: 4.35ft

Stop Sequence:

#	N#	Color	St.	Code	Name	Chart
1.	16		642	0	R254 G254 B254	User-defined
2.	17		62	0	R250 G200 B10	User-defined

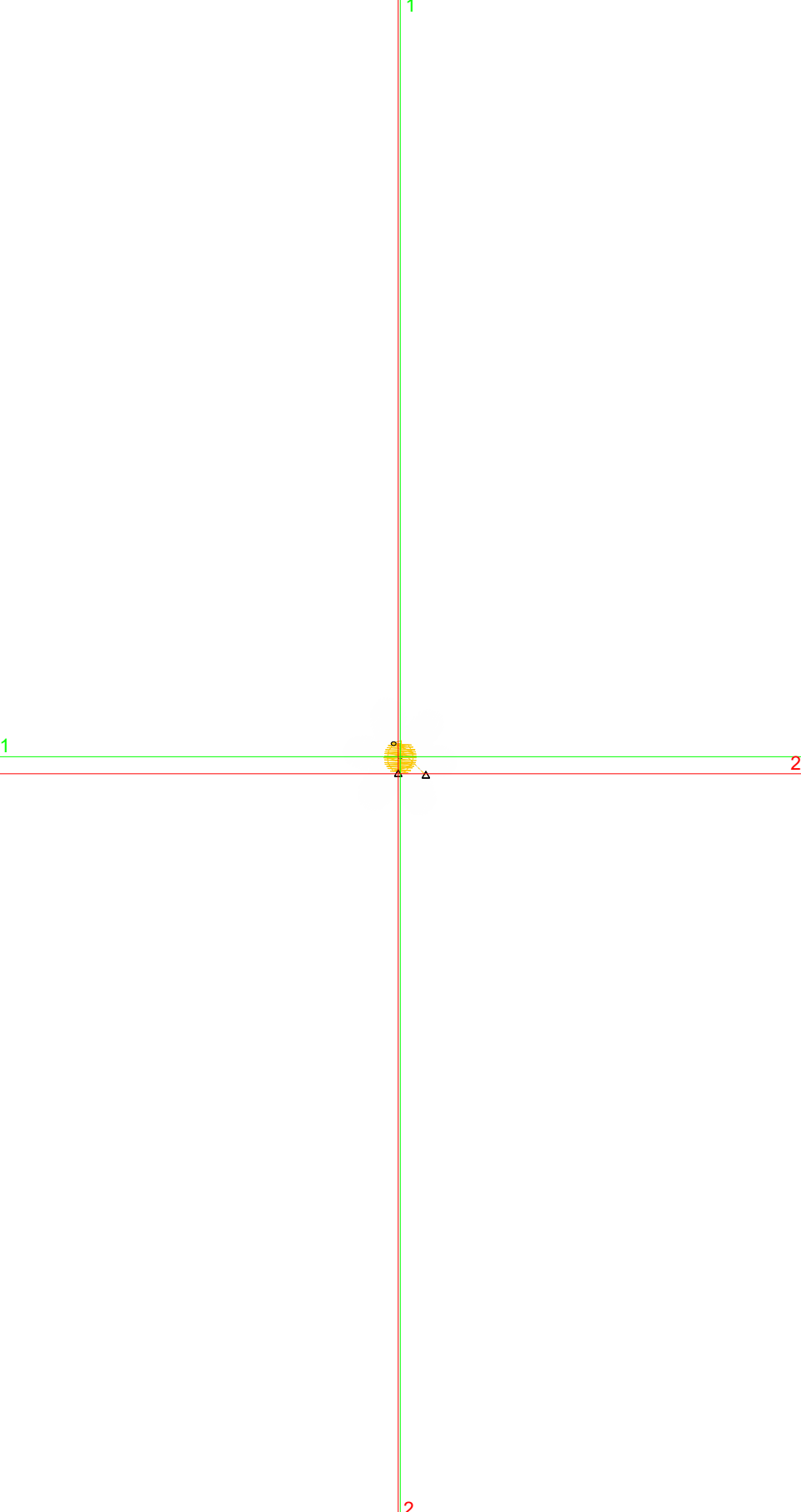

Production Worksheet

Wilcom EmbroideryStudio - Designing



Design: **Design6**

Title:

Stitches: 1,990
 Height: 1.19 in
 Width: 1.20 in
 Colors: 2
 Colorway: Colorway 1
 Zoom: 1:1

Machine format: Janome
 Color changes: 1
 Stops: 2
 Trims: 2
 Appliqués: 0
 Left: 15.2 mm
 Right: 15.2 mm
 Up: 15.1 mm
 Down: 15.1 mm
 EndX: -0.14 in
 EndY: -0.05 in
 Area: 1.42 in²
 Max stitch: 9.8 mm
 Min stitch: 0.1 mm
 Max jump: 0.0 mm
 Total thread: 37.27ft
 Total bobbin: 13.96ft

Stop Sequence:

#	N#	Color	St.	Code	Name	Chart
1.	16		1,886	0	R254 G254 B254	User-defined
2.	17		103	0	R250 G200 B10	User-defined

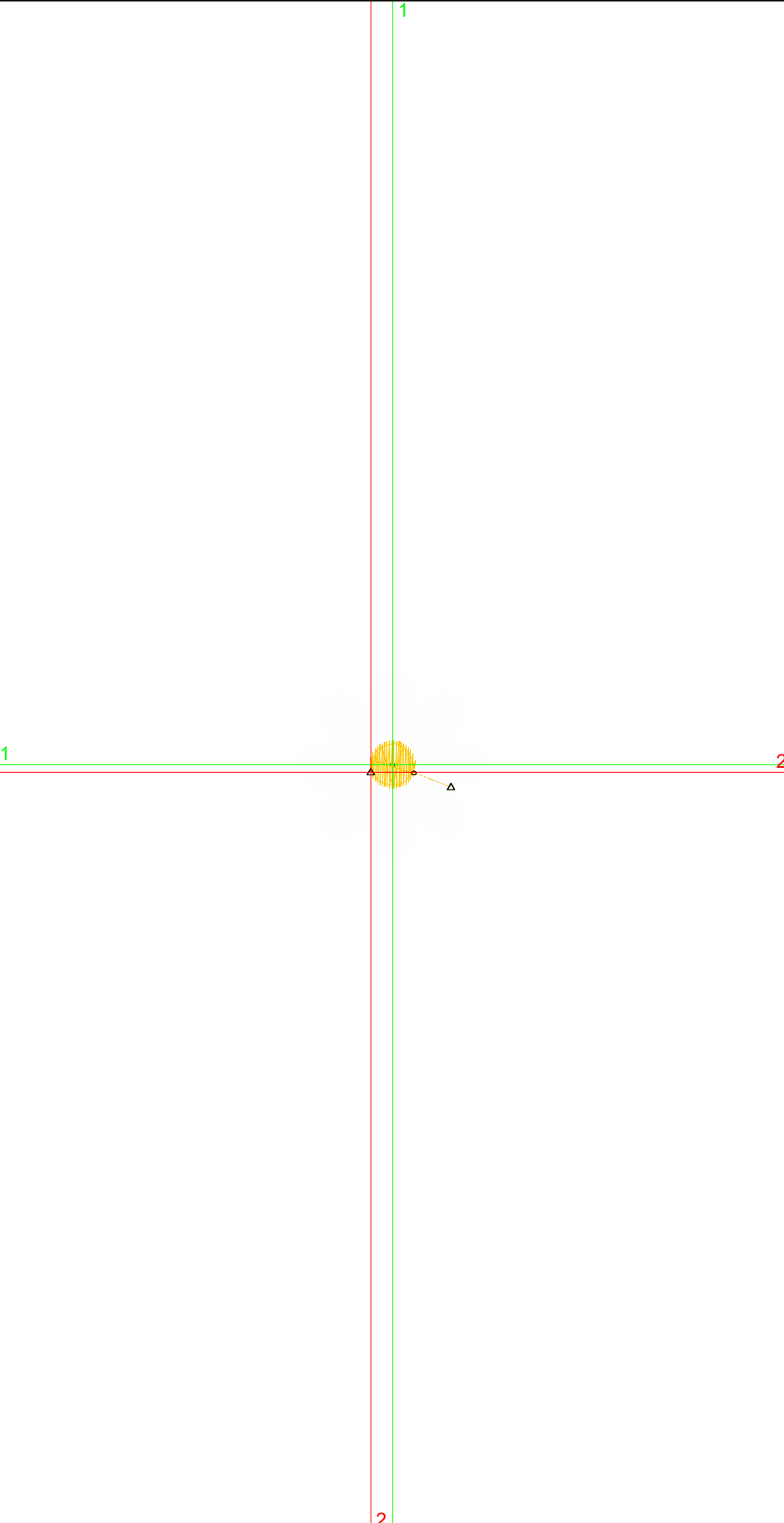

Production Worksheet

Wilcom EmbroideryStudio - Designing



Design: **Design7**

Title:

Stitches: 1,926
 Height: 1.36 in
 Width: 1.36 in
 Colors: 2
 Colorway: Colorway 1
 Zoom: 1:1

Machine format: Janome
 Color changes: 1
 Stops: 2
 Trims: 2
 Appliqués: 0
 Left: 17.3 mm
 Right: 17.3 mm
 Up: 17.3 mm
 Down: 17.3 mm
 EndX: -0.20 in
 EndY: 0.68 in
 Area: 1.86 in²
 Max stitch: 10.0 mm
 Min stitch: 0.3 mm
 Max jump: 0.0 mm
 Total thread: 34.97ft
 Total bobbin: 12.84ft

Stop Sequence:

#	N#	Color	St.	Code	Name	Chart
1.	16		474	0	R249 G200 B10	User-defined
2.	17		1,451	0	R254 G254 B254	User-defined

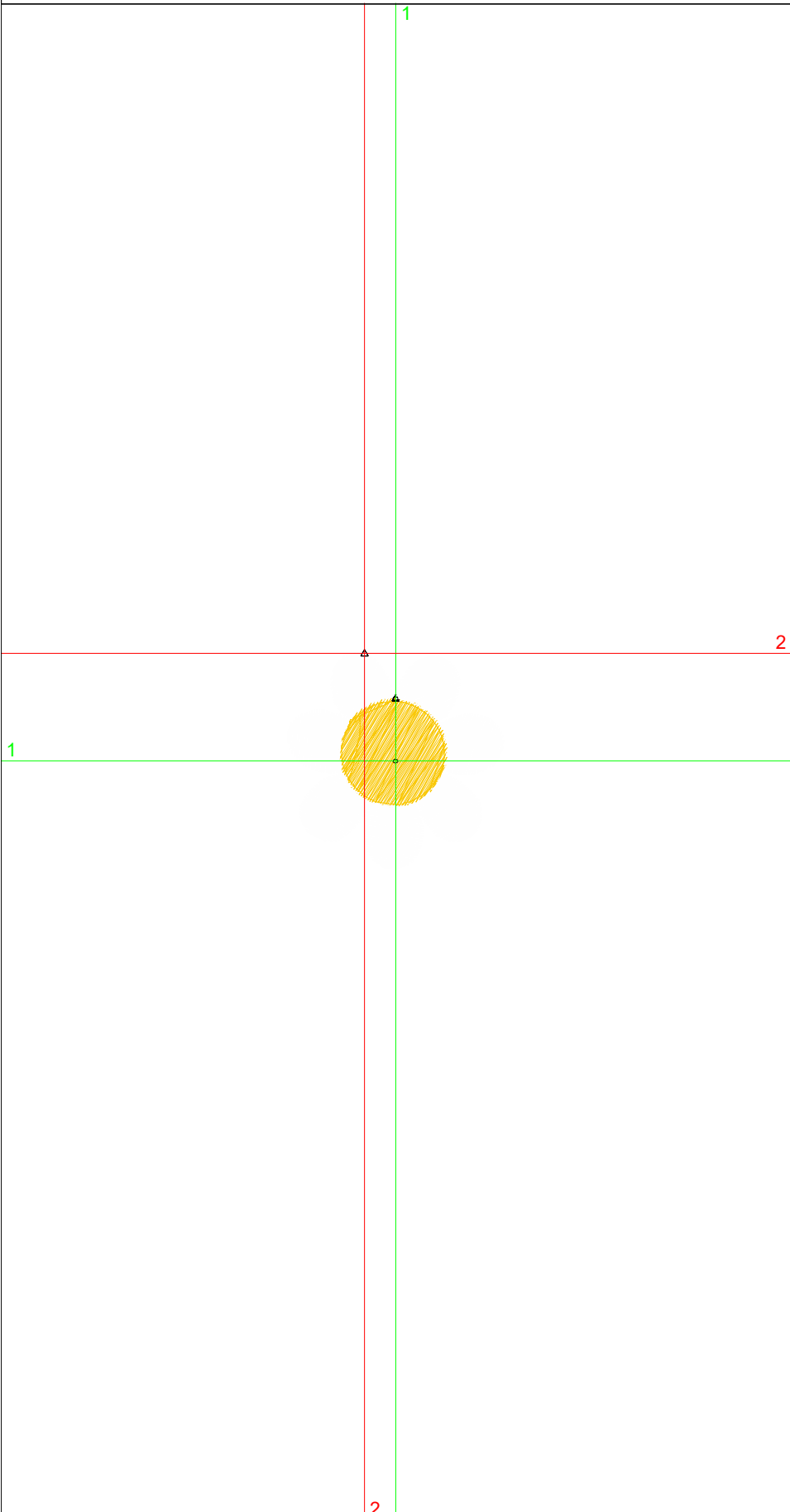

Production Worksheet

Wilcom EmbroideryStudio - Designing



Design: **Design8**

Title:

Stitches: 1,509
 Height: 1.39 in
 Width: 1.27 in
 Colors: 2
 Colorway: Colorway 1
 Zoom: 1:1

Machine format: Janome
 Color changes: 1
 Stops: 2
 Trims: 2
 Appliqués: 0
 Left: 16.1 mm
 Right: 16.1 mm
 Up: 17.7 mm
 Down: 17.7 mm
 EndX: -0.04 in
 EndY: -0.70 in
 Area: 1.77 in²
 Max stitch: 5.4 mm
 Min stitch: 0.3 mm
 Max jump: 0.0 mm
 Total thread: 28.42ft
 Total bobbin: 10.58ft

Stop Sequence:

#	N#	Color	St.	Code	Name	Chart
1.	16		241	0	R250 G200 B10	User-defined
2.	17		1,267	0	R254 G254 B254	User-defined

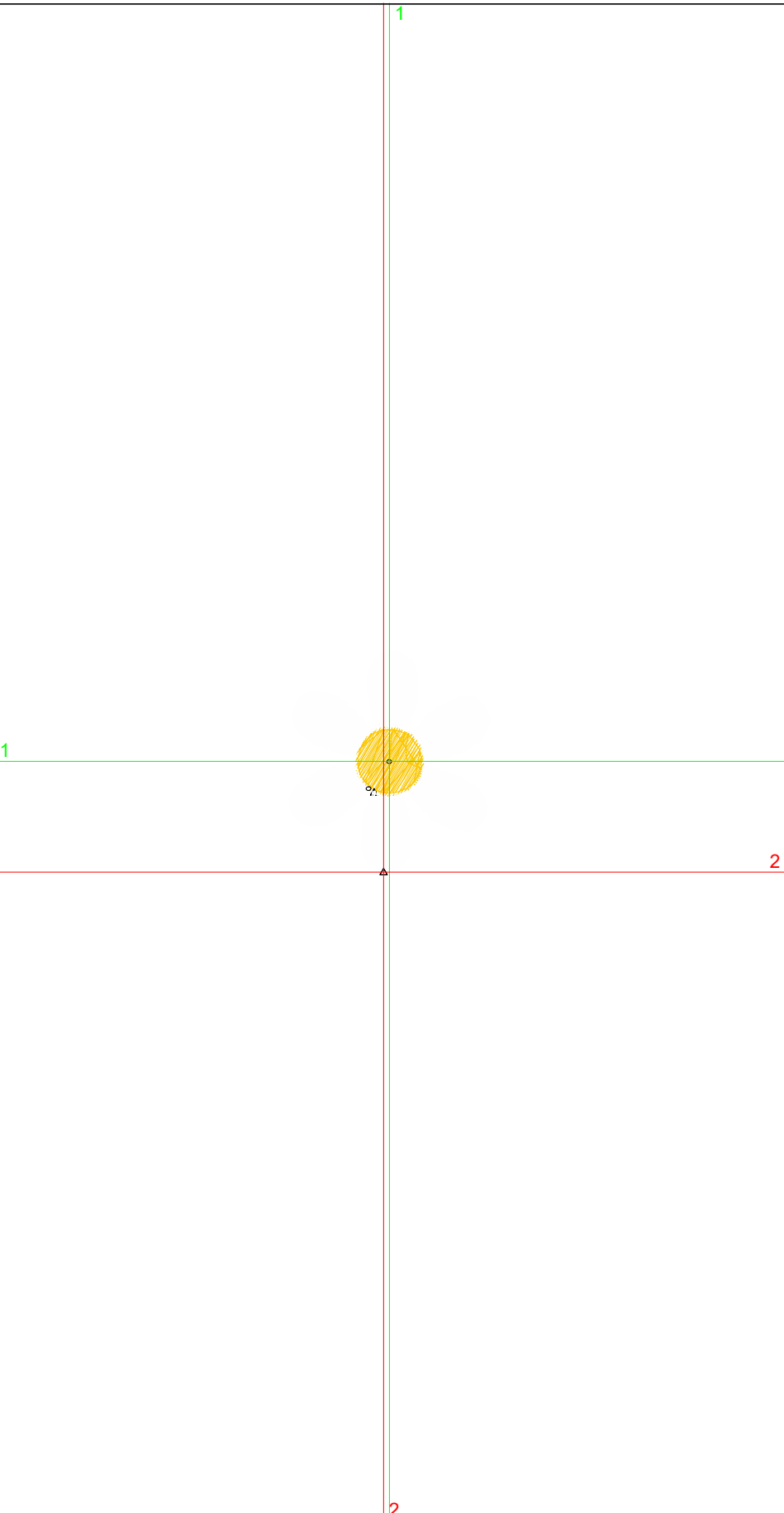

Production Worksheet

Wilcom EmbroideryStudio - Designing



Design: **Design9**

Title:

Stitches: 2,503
 Height: 1.42 in
 Width: 1.37 in
 Colors: 2
 Colorway: Colorway 1
 Zoom: 1:1

Machine format: Janome
 Color changes: 1
 Stops: 2
 Trims: 2
 Appliqués: 0
 Left: 17.4 mm
 Right: 17.3 mm
 Up: 18.0 mm
 Down: 18.0 mm
 EndX: -0.15 in
 EndY: -0.06 in
 Area: 1.94 in²
 Max stitch: 6.4 mm
 Min stitch: 0.3 mm
 Max jump: 0.0 mm
 Total thread: 47.73ft
 Total bobbin: 18.16ft

Stop Sequence:

#	N#	Color	St.	Code	Name	Chart
1.	16		2,343	0	R254 G254 B254	User-defined
2.	17		159	0	R250 G200 B10	User-defined

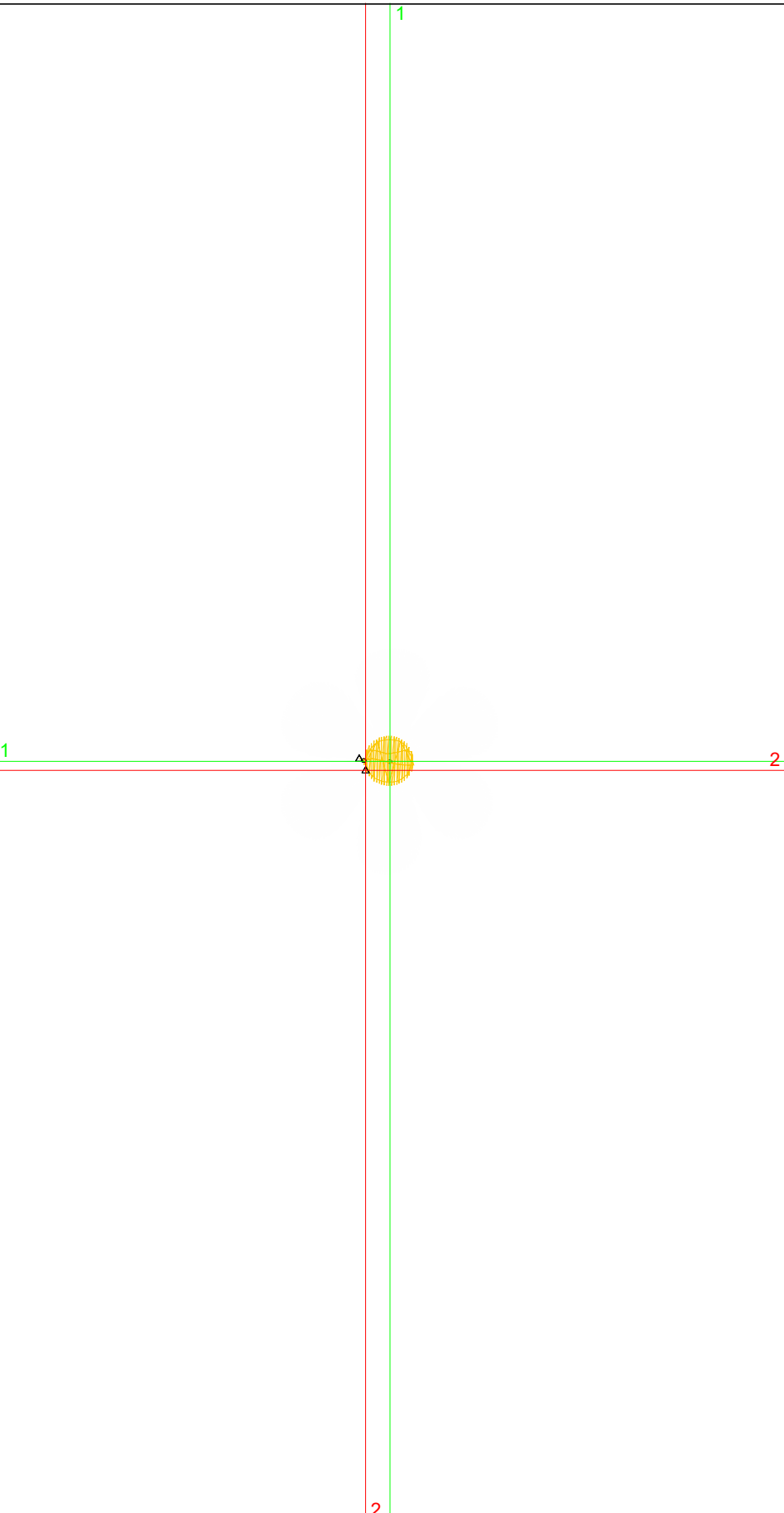

Production Worksheet

Wilcom EmbroideryStudio - Designing



Design: **Design10**

Title:

Stitches: 4,189
 Height: 1.90 in
 Width: 1.83 in
 Colors: 2
 Colorway: Colorway 1
 Zoom: 1:1

Machine format: Janome
 Color changes: 1
 Stops: 2
 Trims: 2
 Appliqués: 0
 Left: 23.2 mm
 Right: 23.2 mm
 Up: 24.1 mm
 Down: 24.1 mm
 EndX: -0.18 in
 EndY: 0.16 in
 Area: 3.47 in²
 Max stitch: 10.9 mm
 Min stitch: 0.3 mm
 Max jump: 0.0 mm
 Total thread: 86.91ft
 Total bobbin: 34.82ft

Stop Sequence:

#	N#	Color	St.	Code	Name	Chart
1.	16		3,960	0	R253 G253 B253	User-defined
2.	17		228	0	R249 G200 B10	User-defined

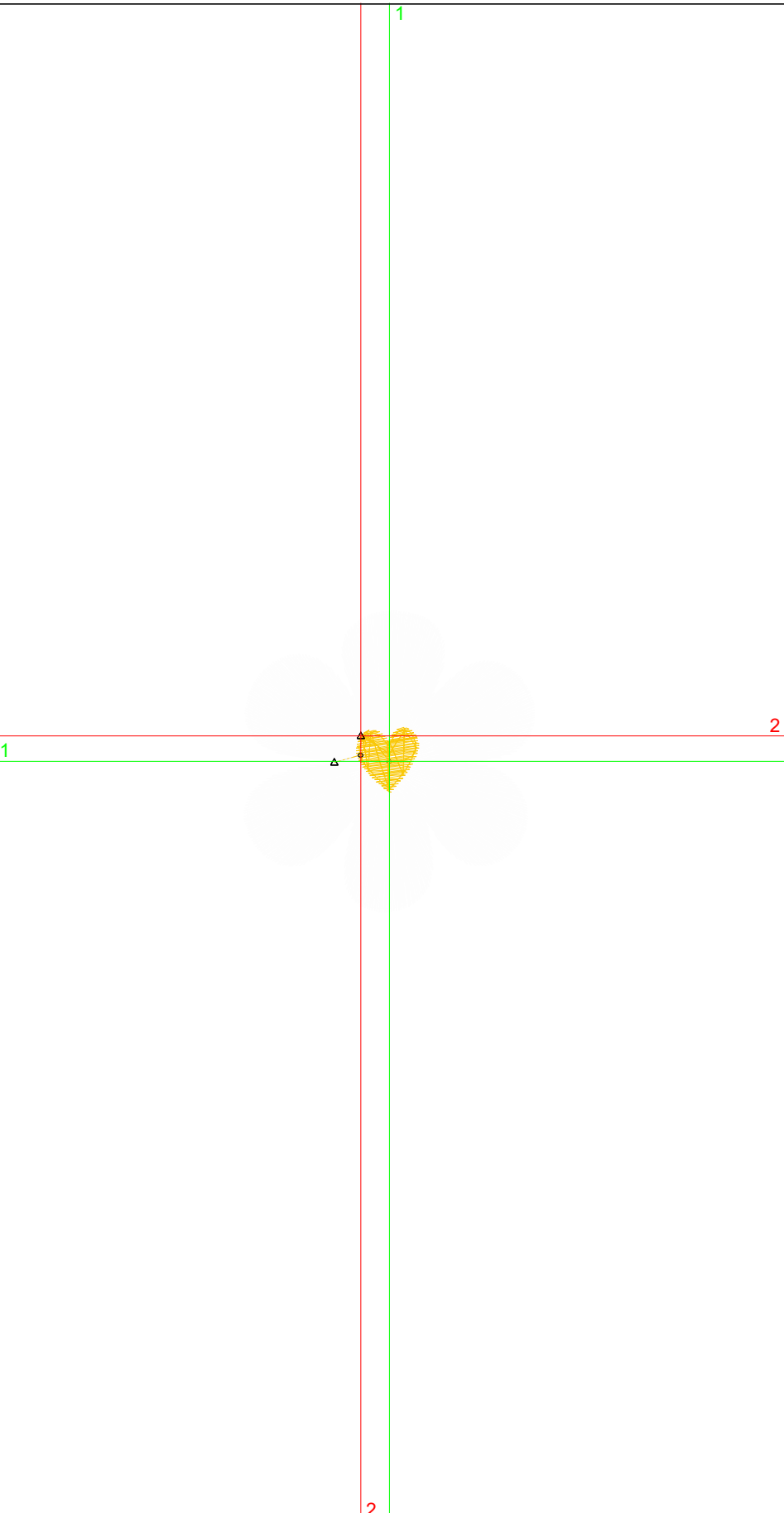

Production Worksheet

Wilcom EmbroideryStudio - Designing



Design: **Design11**

Title:

Stitches: 2,606
 Height: 1.44 in
 Width: 1.43 in
 Colors: 2
 Colorway: Colorway 1
 Zoom: 1:1

Machine format: Janome
 Color changes: 1
 Stops: 2
 Trims: 2
 Appliqués: 0
 Left: 18.1 mm
 Right: 18.1 mm
 Up: 18.3 mm
 Down: 18.4 mm
 EndX: -0.23 in
 EndY: 0.13 in
 Area: 2.06 in²
 Max stitch: 11.8 mm
 Min stitch: 0.3 mm
 Max jump: 0.0 mm
 Total thread: 50.10ft
 Total bobbin: 19.16ft

Stop Sequence:

#	N#	Color	St.	Code	Name	Chart
1.	16		2,360	9	White	User-defined
2.	17		245	0	R250 G200 B10	User-defined

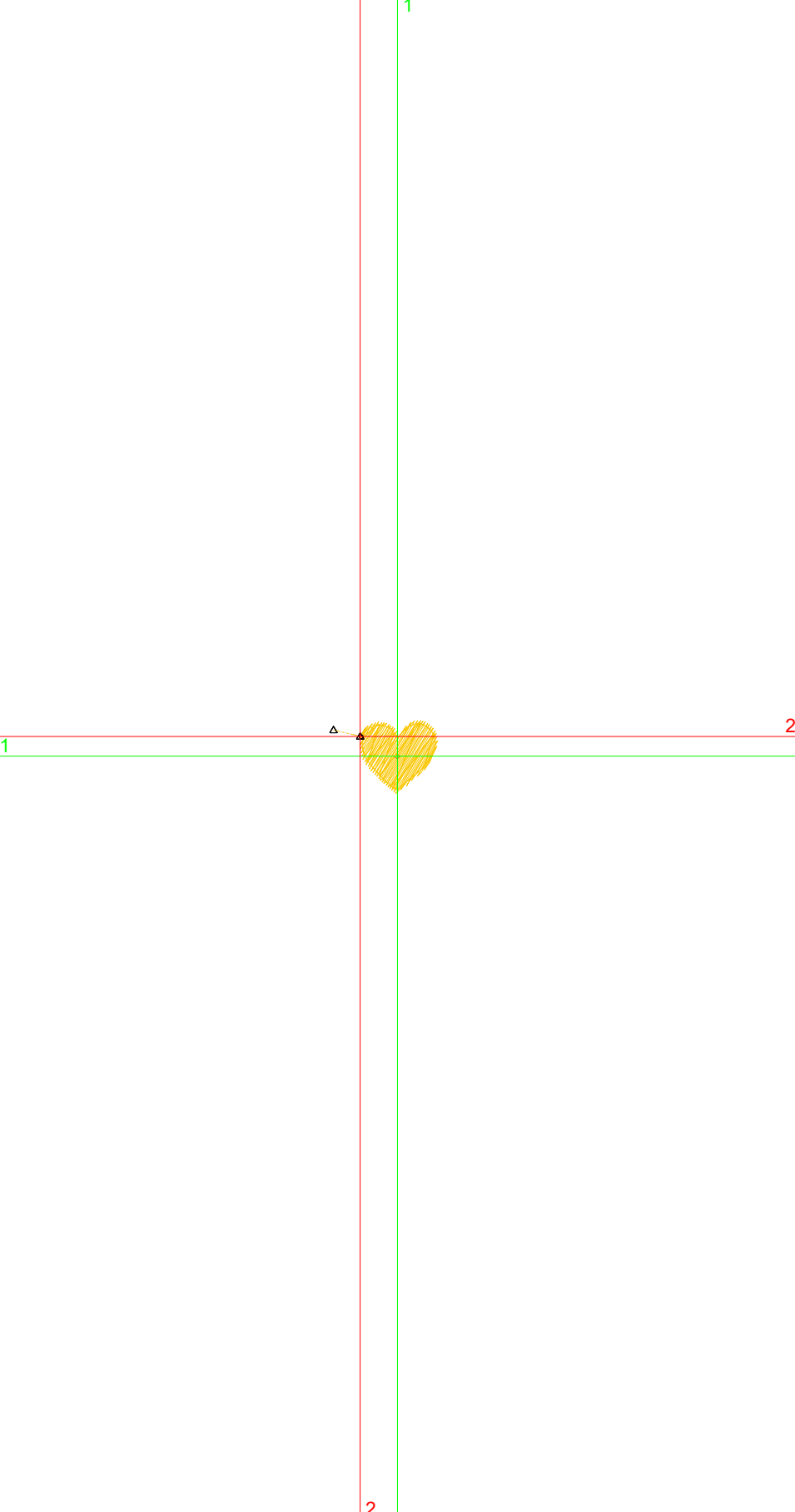

Production Worksheet

Wilcom EmbroideryStudio - Designing



Design: **Grouped Daises Design12**

Title:

Stitches: 25,609
Height: 6.79 in
Width: 7.48 in
Colors: 2
Colorway: Colorway 1
Zoom: 1:1

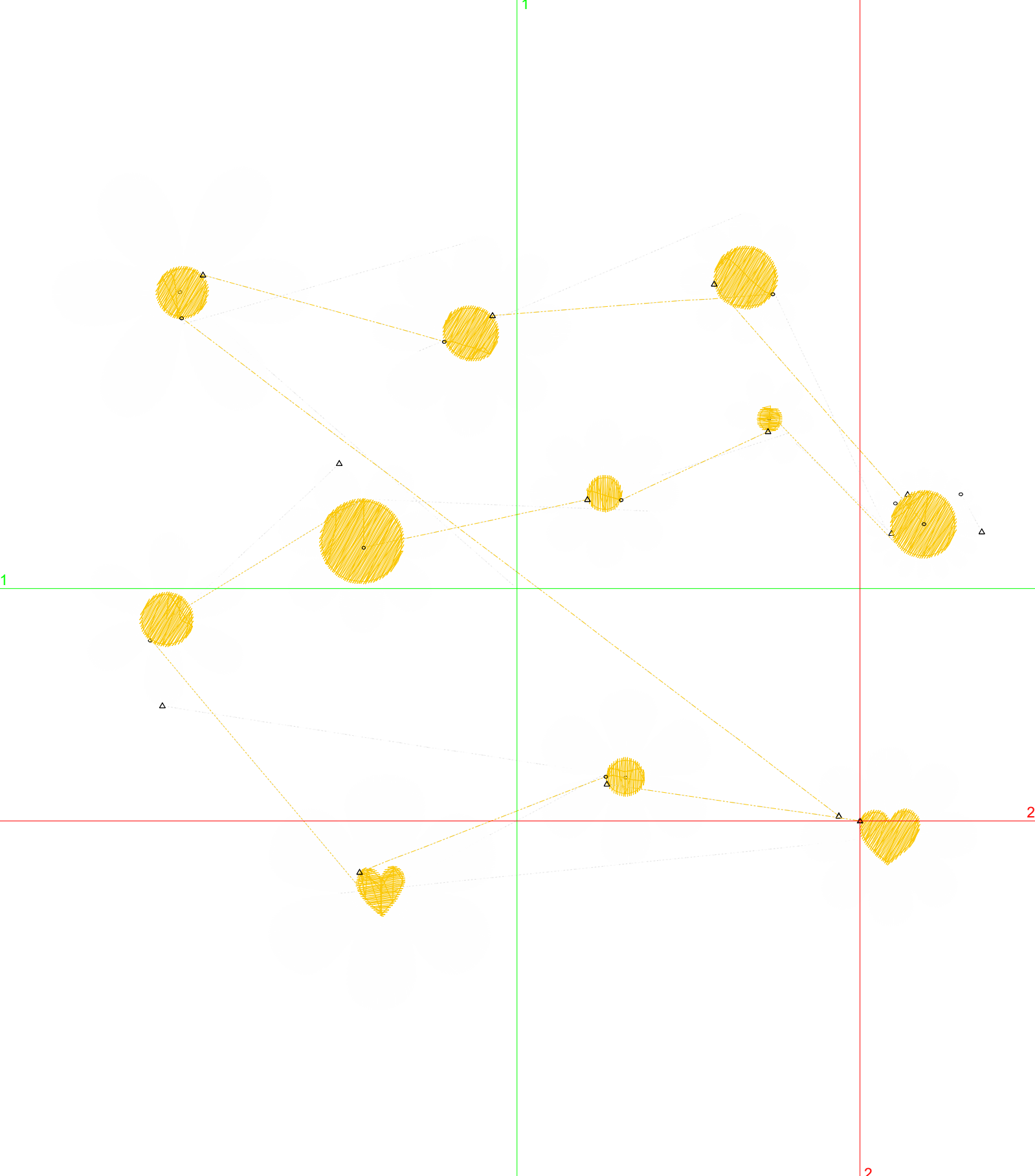

Production Worksheet

Wilcom EmbroideryStudio - Designing



Stitches: 25,609
 Height: 6.79 in
 Width: 7.48 in
 Colors: 2
 Colorway: Colorway 1
 Zoom: 1:1

Design: **Grouped Daises Design12**

Title:

Machine format: Janome
 Color changes: 1
 Stops: 2
 Trims: 14
 Appliqués: 0
 Left: 95.0 mm
 Right: 95.0 mm
 Up: 86.2 mm
 Down: 86.2 mm
 EndX: 2.76 in
 EndY: -1.87 in
 Area 50.77 in²
 Max stitch: 12.6 mm
 Min stitch: 0.1 mm
 Max jump: 12.6 mm
 Total thread: 489.56ft
 Total bobbin: 190.14ft

Stop Sequence:

#	N#	Color	St.	Code	Name	Chart
1.	16		22,911	0	R254 G254 B254	User-defined
2.	17		2,697	0	R250 G200 B10	User-defined